

ENGLISH

INTELLIGENT OUTDOOR DETECTOR

Installation instructions

1. INTRODUCTION

The detector is a special three-tech (PIR+PIR+MW) complex detector for outdoor intrusion. Signals of 3 sensors are with super stability and dependability by its advanced multi-grades digital signal processing technology. And they can offer 3 different detection modes on 2 sensitive grades in order to choose the best the detection way for spot environment and gets the best rate between the best detection ability and the minimum false alarm rate. With normal "AND" and "OR" modes, The detector is also with "5P" mode to avoid the damage of dopes spraying on the lens. Its unique water-proof design is totally fit for outdoor installation. At the same time, the detector also provides the installation user with NO/NC output selection mode, which can be directly used to activate THE CCTV system and access control system.

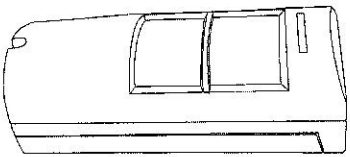

2. BRIEF INTRODUCTION

- Two PIR and MW detection tech
 - Automatic setting of anti-masking
 - Microwave synchronization
 - Detection mode: MW/SP-OR- AND
 - Selectable detection sensitivity
 - Alarm output NO/NC Select
 - Anti White Light
 - Anti-pet $\geq 25kg$
- Alternative Led OFF
 - Micro-strip MW with pulse transmission
 - 62 beams Fresnel lens with down-view window on its 6 planes
 - Vertical adjustment
 - Air-proof optical parts
 - Wall inlay
 - Total view: 100° , Monitoring scale: 15m
 - Corner and wall installation. Universal connector
 - Universal connector for option.
 - 90° horizontal adjustment 30° vertical adjustment

3. SPECIFICATIONS

- Power supply:** 12-24VDC
Current: 30mA
Install high: 1.5m-2.4m
MW frequency: 10.525GHz
MW power(ERP): 13dBm
PIR sensor: 2X Dual elements
Alarm time: 3s
Anti RF: 0.1-1000MHz/30V/m
Anti-white light: >100000LUX
Anti EMI: 50000V
Anti petweight: 25Kg
Alarm output: NC/NO @2A/24VDC
Mask output: 100mA/24V
Temperature: -25°C/+55°C
Storage temp: -40°C/+65°C
Humidity(RH): 95%
Sensitivity: H/L Select
Detect speed: 0.2m/s to 3.5m/s
shell material: ABS Resin
- Dimensions (H×W×D):** 180mm×76mm×60mm
Coverage: 12m×12m 100° (wide lens)

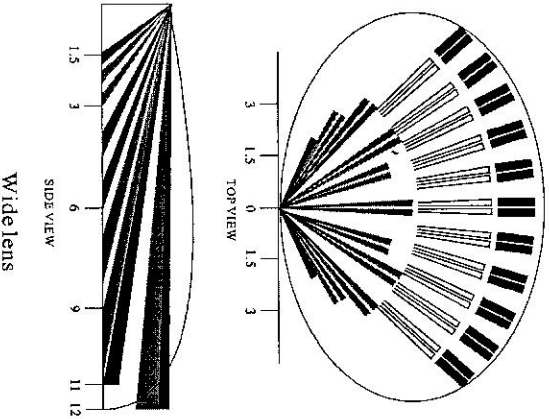

4. INSTALLATION GUIDE

Select the best installation point fit for PIR and MW technologies. Put detector onto the selected place and keep it away from door, window, running machine or heat sources.

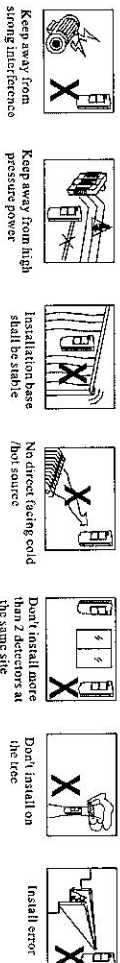

5. WALL FASTENING

In order to get the best signal covering scale, detector should be installed on 2.1m height and vertical adjustment to position A. Anyhow, detector can be installed to maximum 4m height. Make sure that there are no counterwork in front of the detector and it is with a wide view.

Remove the front cover, release the screws and then pull out the PCB. Break the pre-set hole, if necessary, disclose the "wall inlay pre-set hole" and tear open once "wiring hole"; mark the point of the hole on wall and put the "wall inlay" label on the pre-set hole. Drill 3 6mm holes and screw in the "wall inlay screws", let its front extremity be 5/6 mm from the wall. Cross the wire from the cable hole and fasten the bottom cover onto the wall, confirm its from extremity enter the oblique site.

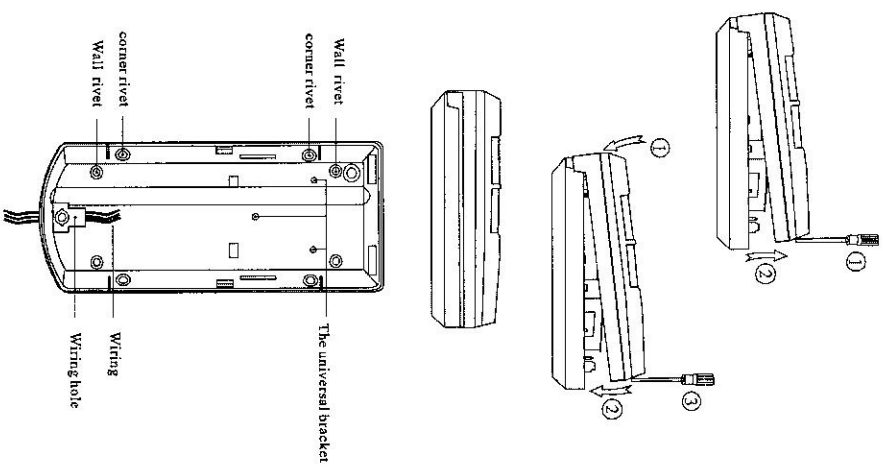

About installation Angle

There is a physical difference in the Angle of intrusion.

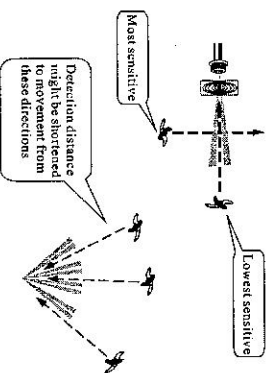

About Installation Position

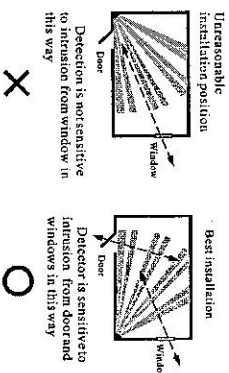

6. PART EXPLAIN

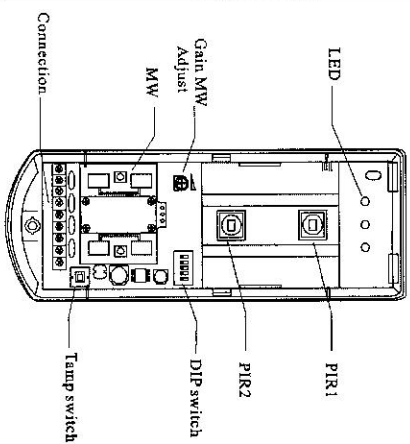

7. TESTING

DIP 1 switch on "OFF" (anti masking cover "OFF")
DIP 5 switch on "OFF" (LED actives)

Note:
During this stage, anti-masking is limited.

MW

Tune microwave tuner to minimum. Capacity can be adjusted from 2-15m : to the extremity of protection area, when LED indicator turns off, operation radar movement to the detector, check MW detection by green LED. If green LED doesn't light, turn the MW tuner in clock wise to increase its capacity; repeat this test for several times till you get the required distance. Remarks: MW adjustment: turn the capacity to the minimum, for MW can penetrate wall while over high capacity is not helpful for detector function in its protection area. (MW gets highest sensitivity when it performs radial movement to detectors)

PIR

Close the front cover, when LED indicator turns off, perform horizontal movement in the detection area, check the detection status of PIR through the yellow LED. This step can check whether there is dead corner in the detection area, when PIR gets highest sensitivity when horizontal movement to detector. When all DIP switches are in "OFF" status, monitor is in standard operation.

Anti-mask cover control/AND/high sensitivity/LED activation If want to get max. monitoring, please refer to "monitoring mode" section.

Note: When there is interference to the monitor, anti-masking cover function will be limited.

8. MONITORING MODE

AND

DIP 2 switch on "OFF" status
If three sensors (2*PIR&MW) get the detection signal at the same time, alarm will be trigger.
This mode is fit for installation with unstable factors.

OR

DIP 2 switch in "ON" position
Any of these sensors gets detection signal, alarm will be triggered. This mode is fit for high stable environment and inquires the detector with very high detection ability.

5P (MODE)

DIP 3 switch is in "ON" position
During the status, DIP 2 switch is useless.
If three sensors get the detection signal at the same time, (such as AND mode), or if they get more MW signal while there isn't any 2*PIR signal, alarm conditions are provided.
Fit for the installation which needs "AND" detection mode, but it may exist PIR shadow area, or somebody spray the dope onto the PIR lens willfully to damage the PIR detection.

SENS I

DIP 4 switch is in "ON" position
Detection sensitivity of both sensors are reduced.

PIR: During the time, signals detected by both negative and positive period of PIR are limited.

MW: the detection response speed of MW is 0.5 seconds, running speed is 0.6m/second.

ON	1	2	3	4	5
	ON	LOCK	ON	5P	SENS I
	OFF	AND		5P	LED

MW RANGE

Time	9	10	11	12	1	2	3
Range	2m	4m	6m	8m	9m	12m	15m

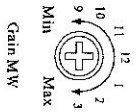

TEST PATH

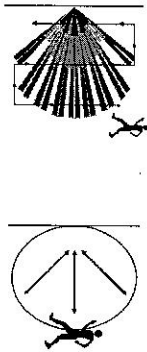

LED DISPLAY



9. FUNCTION

Anti-masking function

Anti object block the MW may cause alarm by the twinkle of LED indicator, and the signal is transported to monitoring center by MASK connector. Alarm status will last till the cause of formation are cleared away.

Activation of anti-masking function

DIP 1 switch is in "ON" position
The activation of anti-masking function is the final operation. After activation, detector enters self-check status: during the time, LED indicator will twinkle for 100 seconds. During the time, close the front cover and keep away from the detector, detector will enter automatic setting status and perform automatic adjustment of anti-masking height. The most important point is, during the time, there is anything approaching the detector to avoid its automatic setting.

LED OFF

DIP 5 switch
In "ON" position, it will limit detection display.

MW OFF

DIP 1 switch is in "OFF" position
DIP 5 switch is in "ON" position

Note:
During this mode, anti-masking is limited.

LED DISPLAY

ALARM	Green Led	Red/Blue Led	Yellow Led
PIR-MW	OFF	ON	OFF
PIR	OFF	ON	ON
MW	ON	ON	OFF
MASK	FLASH	FLASH	FLASH

10. WIRE UP THE TERMINAL

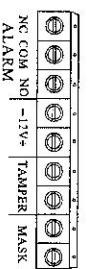

Alarm output, with normally closed normally open optional, select normally closed; normally closed under normal conditions, open when alarm; normally open; normally open and closed when alarming (can directly trigger access control system and CCTV system)

Power supply 12-24VDC input, power flow minimum 50 mA

TAMPER

The contact is closed normally, if remove the front small cover or the whole detector from the wall, contact will open. (Sensor connects with wall in lay style monitor)

MASK
Anti masking cover output, contact is closed when it is normal.

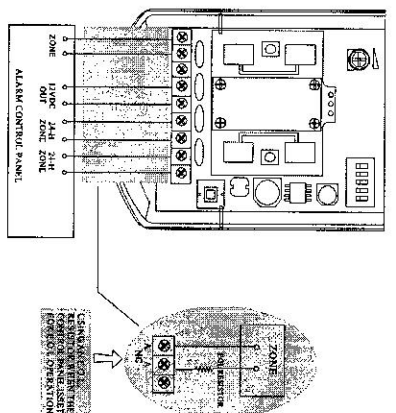

11. VERTICAL ADJUST

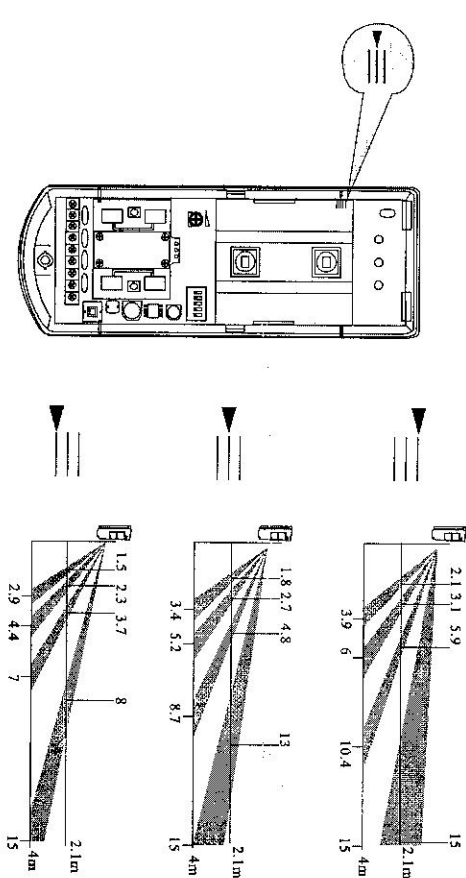

12. NOTES AND WARNINGS

Even the most sophisticated detectors can sometimes be defeated or may fail to warn due to: DC power failure/improper connection, malicious masking of the lens/lampening with the optical system, decreased sensitivity in ambient temperatures near that of the human body and unexpected failure of a component part. The above list includes the most common reasons for failure recommended that the detector and the entire alarm system be checked weekly, to ensure proper performance. An alarm system should not be regarded as a substitute for insurance. Home & property owners or renters should be prudent enough to continue insuring their lives & property, even though they are protected by an alarm system.

This device has been tested and found to comply with the limits for a Class B digital device, pursuant to part 15 of FCC Part 15.21 of the Federal Communications Commission (FCC) Rules and Regulations. This equipment generates, uses and can radiate radio frequency energy and, if not installed and used in accordance with the instructions, may cause harmful interference to radio and television reception. However, there is no guarantee that interference will not occur in a particular installation. If this device does cause such interference, which can be verified by turning the device off and on, the user is encouraged to eliminate the interference by one or more of the following measures:
- Increase the distance between the device and the receiver.
- Connect the device to an outlet on a circuit different from the one that supplies power to the receiver.
- Consult the dealer or an experienced radio/TV technician.

WARNING! Changes or modifications to this unit not expressly approved by the party responsible for compliance could void the user's authority to operate the equipment.